

 **SYNERGEE®**

MULTI-GRIP BAR

MANUAL

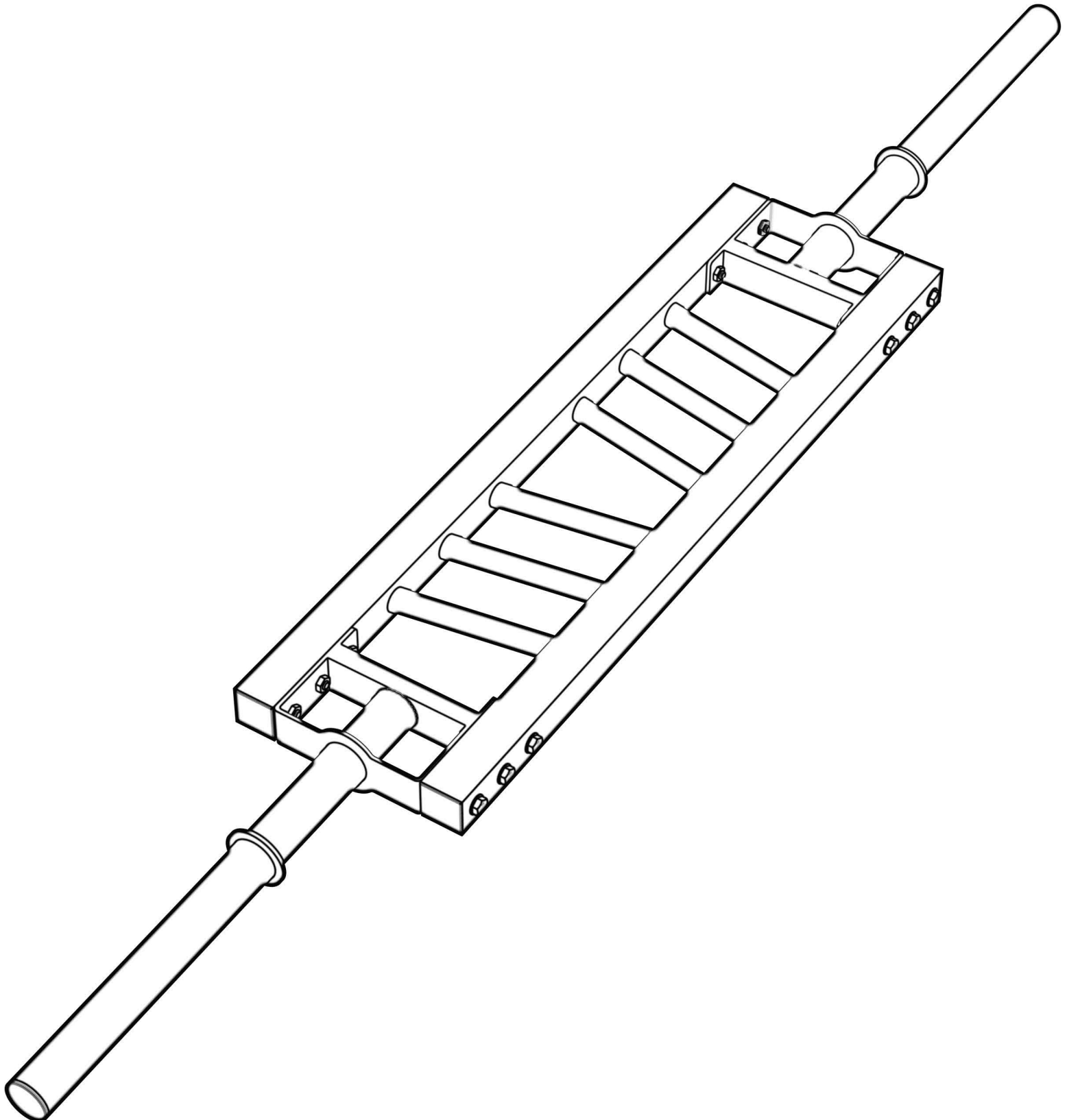

KEY	PART	QTY
1.	BAR FRAME	1
2.	PLATE LOADERS	2
3.	M10X65 BOLT	12
4.	M10 NUT	12
5.	M10 WASHER	24

**IF ANY PIECES ARE MISSING, PLEASE CONTACT US IMMEDIATELY:
HELLO@SYNERGEEFITNESS.COM OR 1.855.217.7136**

1.

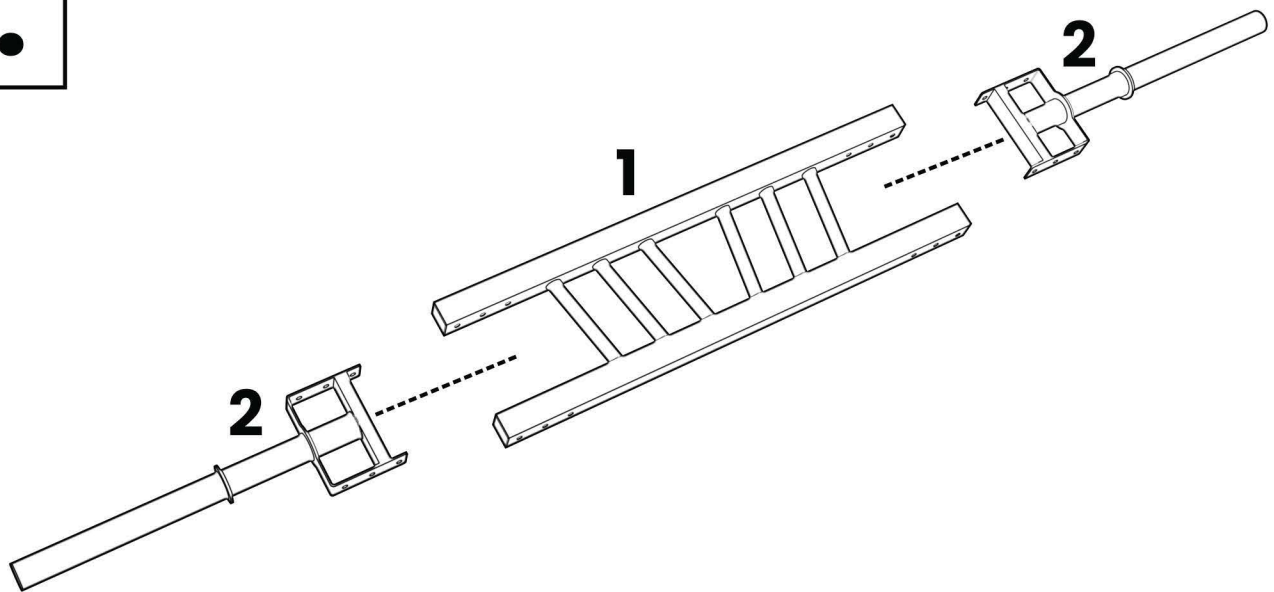

Align the plate holder to the inside of the bar frame as illustrated.

2.

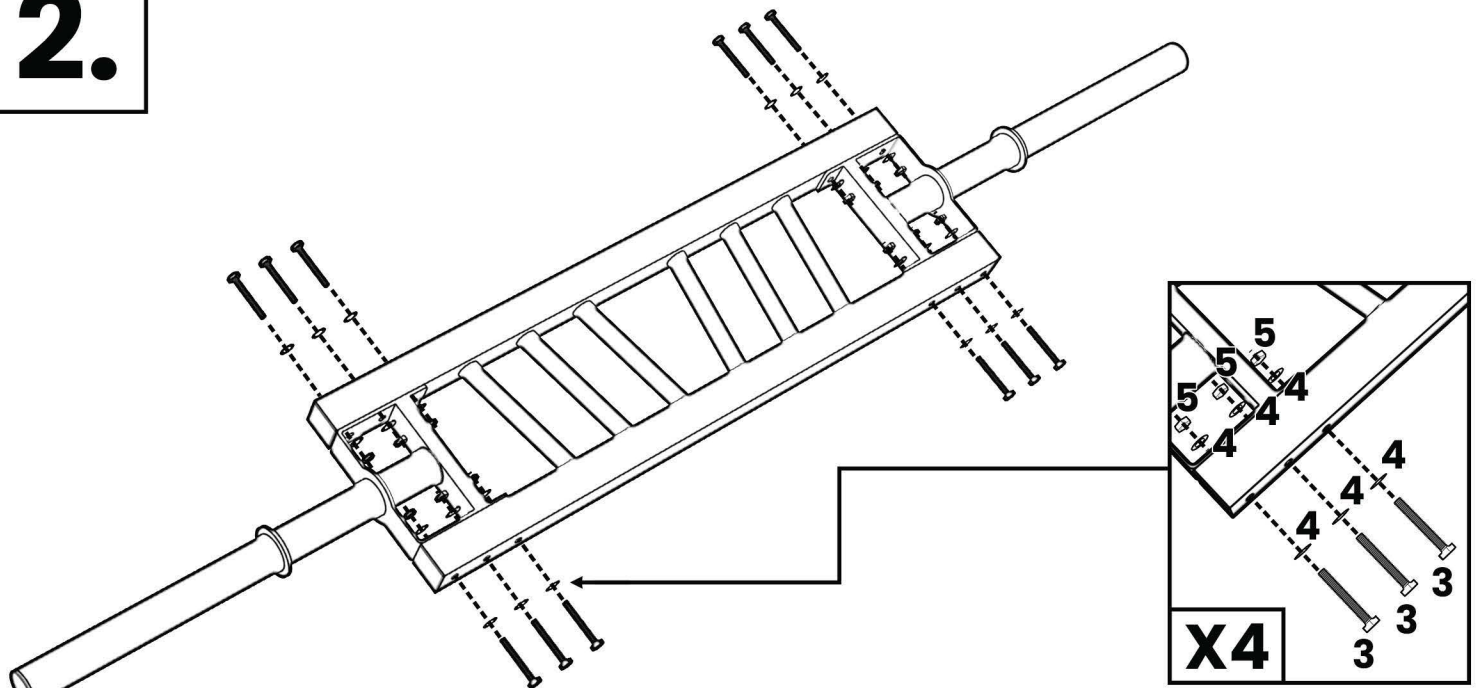

Secure the plate loader to the bar base as shown in all four corners.