

SYNERGEE[®] **Weight Bar Rack**

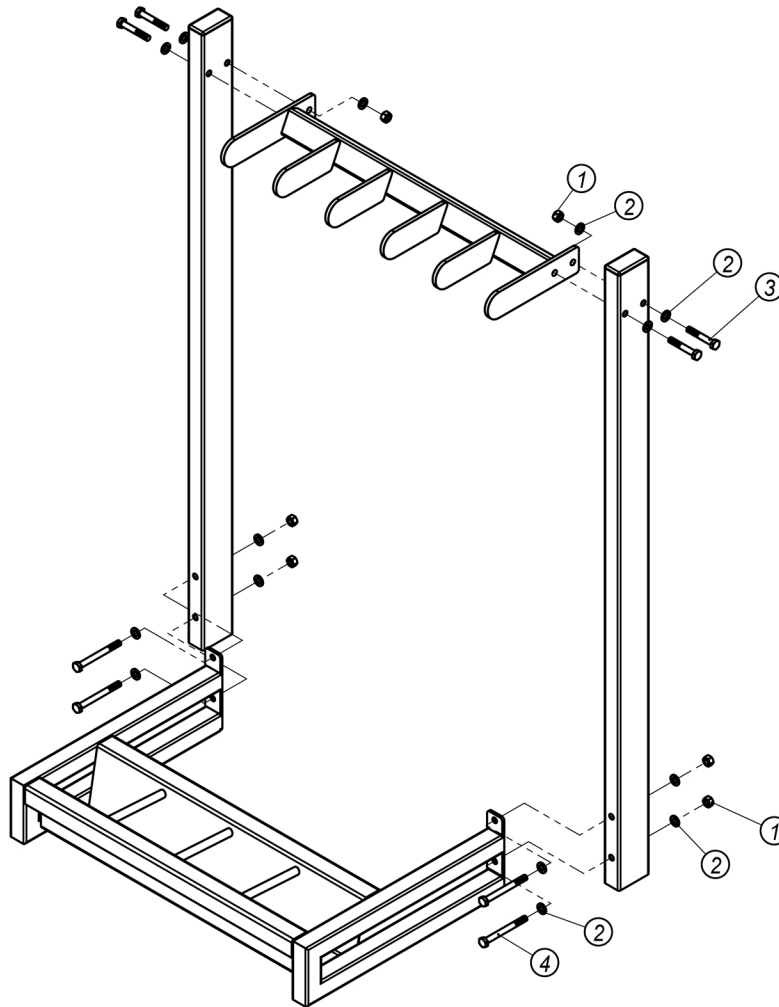

No.	DESCRIPTION	Q'TY
1	Lock Nut M8	6
2	Washer $\Phi 8$	14
3	Bolt M8X50	4
4	Bolt M8X80	4